

# Walter HSK40 // stepped Shaft $\varnothing 20, \varnothing 32$ // RS $\varnothing 50$ and $\varnothing 60$ mm

For Walter tool grinding machines with ring set  $\varnothing 50$  and  $\varnothing 60$  mm

**GWA HSK40 // stepped  $\varnothing 20 \varnothing 32$  mm // RS  $\varnothing 50 \varnothing 60$  mm**

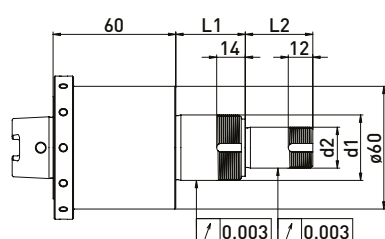
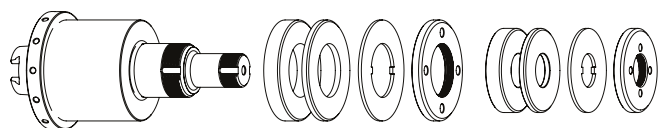

### Delivered equipped:

Ring set  $\varnothing 50$  and  $\varnothing 60$  mm, lock washer and clamping nut

Order No.	HSK	d1	d2	L1	L2	Ring set $\varnothing 50$ mm		Ring set $\varnothing 60$ mm	
						B 20	B 4	B 10	B 4
300103012	HSK40	32	20	34	33	1	2	1	2

## Accessories Walter grinding wheel adapter HSK40 // stepped Shaft $\varnothing 20, \varnothing 30$ // RS $\varnothing 50$ and $\varnothing 60$ mm

### Accessories $\varnothing 50$ mm

Order No.	Name	
350011020	Spacer ring $\varnothing 50 \times \varnothing 20 \times 20$	
350011010	Spacer ring $\varnothing 50 \times \varnothing 20 \times 10$	
350011004	Spacer ring $\varnothing 50 \times \varnothing 20 \times 4$	
350030010	Lock washer $\varnothing 50 \times \varnothing 20 \times 2$	
350020060	Clamping nut $\varnothing 50 \times 6 \times M20 \times 1$ PC27	
350020020	*Clamping nut with balancing option $\varnothing 50 \times 8,5 M20 \times 1,0$ PC27	
350020021	*Balancing weight pair for clamping nut $\varnothing 50$ // 100gmm	
350040010	*Clamping nut wrench PC27 for $\varnothing 20$	
350040011	*Clamping nut wrench PC27 for $\varnothing 20$	

### Accessories $\varnothing 60$ mm

Order No.	Name	
350011320	Spacer ring $\varnothing 60 \times \varnothing 32 \times 20$	
350011310	Spacer ring $\varnothing 60 \times \varnothing 32 \times 10$	
350011304	Spacer ring $\varnothing 60 \times \varnothing 32 \times 4$	
350030060	Lock washer $\varnothing 60 \times \varnothing 32 \times 1,8$	
350020065	Clamping nut $\varnothing 60 \times 6 \times M32 \times 1$ PC45	
350040020	Clamping nut wrench PC45 for $\varnothing 32$	

\*related items

# Walter HSK40 // Shaft $\varnothing 20$ / Shaft $\varnothing 32$ mm // RS $\varnothing 50$ and $\varnothing 60$ mm

For Walter tool grinding machines with ring set  $\varnothing 50$  and  $\varnothing 60$  mm

## GWA HSK40 // $\varnothing 20$ / $\varnothing 32$ mm // RS $\varnothing 50$ / $\varnothing 60$ mm

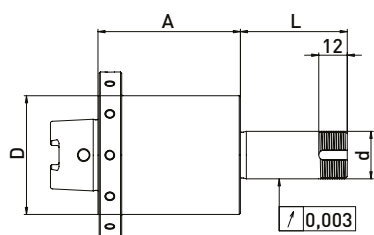
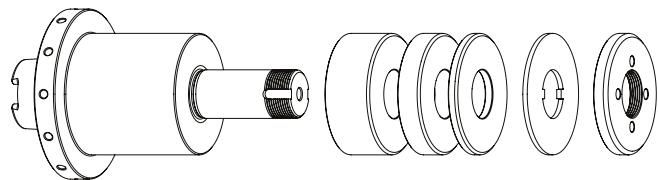

Delivered equipped:

Ring set  $\varnothing 50$  mm or ring set  $\varnothing 60$ , lock washer and clamping nut

## Walter HSK40 // Shaft $\varnothing 20$ // Ring set $\varnothing 50$ mm

Order No.	HSK	d	D	A	L	B 20	B 10	B 4
300103112	HSK40	20	50	60	45	-	2	3
300103122	HSK40	20	50	80	52	1	1	3

### Accessories $\varnothing 50$ mm

Order No.	Name	
350011020	Spacer ring $\varnothing 50 \times \varnothing 20 \times 20$	
350011010	Spacer ring $\varnothing 50 \times \varnothing 20 \times 10$	
350011004	Spacer ring $\varnothing 50 \times \varnothing 20 \times 4$	
350030010	Lock washer $\varnothing 50 \times \varnothing 20 \times 2$	
350020060	Clamping nut $\varnothing 50 \times 6 \times M20 \times 1$ PC27	
350020020	*Clamping nut with balancing option $\varnothing 50 \times 8,5 M20 \times 1,0$ PC27	
350020021	*Balancing weight pair for clamping nut $\varnothing 50$ // 100gmm	
350040010	*Clamping nut wrench PC27 for $\varnothing 20$	
350040011	*Clamping nut wrench PC27 for $\varnothing 20$	

## Walter HSK40 // Shaft $\varnothing 32$ and $31,75$ // Ring set $\varnothing 60$ mm

Order No.	HSK	d	D	A	L	B10	B4
300103132	HSK40	32	60	60	42	2	3
300103142	HSK40	31,75	60	60	45	1	1

### Accessories $\varnothing 60$ mm

Order No.	Name	
350011320	Spacer ring $\varnothing 60 \times \varnothing 32 \times 20$	
350011310	Spacer ring $\varnothing 60 \times \varnothing 32 \times 10$	
350011304	Spacer ring $\varnothing 60 \times \varnothing 32 \times 4$	
350011420	Spacer ring $\varnothing 60 \times \varnothing 31,75 \times 20$	
350011410	Spacer ring $\varnothing 60 \times \varnothing 31,75 \times 10$	
350011404	Spacer ring $\varnothing 60 \times \varnothing 31,75 \times 4$	
350030060	Lock washer $\varnothing 60 \times \varnothing 32 \times 1,8$	
350020066	Clamping nut $\varnothing 60 \times 6 \times M32 \times 1,5$ PC45	
350020022	*Clamping nut with balancing option $\varnothing 60 \times 9 M32 \times 1,5$ PC39	
350040030	*Clamping nut wrench TK39 for clamping nut with blancing option	
350040020	Clamping nut wrench PC45 for $\varnothing 32$	
350020023	*Balancing weight pair for clamping nut $\varnothing 60$ // 200gmm	

# Walter HSK50 // Shaft $\varnothing 20$ mm // RS $\varnothing 35$ mm

For Walter tool grinding machines with ring set  $\varnothing 35$  mm

## GWA HSK50 // $\varnothing 20$ mm // RS $\varnothing 35$ mm

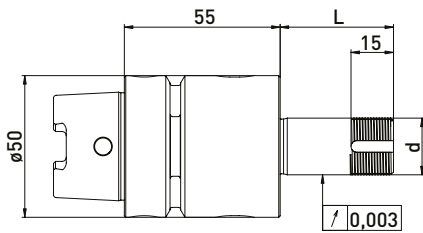
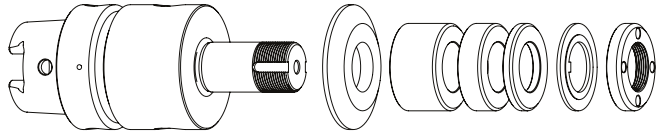

### Delivered equipped:

Reducing washer, ring set  $\varnothing 35$  mm, lock washer and clamping nut

#### Ring set $\varnothing 35$ mm

Order No.	HSK	d	L	B 20	B 10	B 4
300102512	HSK50	20	40	-	1	3
300102522	HSK50	20	60	1	1	3
300102532	HSK50	20	85	2	2	4
300102542	HSK50	20	100	2	3	3

## GWA HSK50 // $\varnothing 20$ mm // without RS

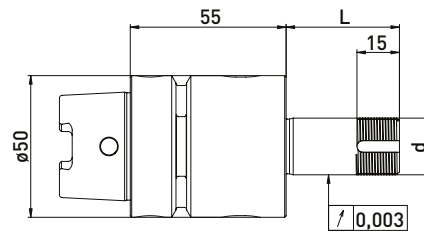
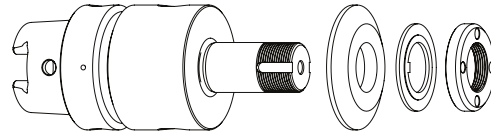

### Delivered equipped:

Reducing washer, lock washer and clamping nut

Order No.	HSK	d	L
300102511	HSK50	20	40
300102521	HSK50	20	60
300102531	HSK50	20	85
300102541	HSK50	20	100

## Accessories Walter grinding wheel adapter HSK50 // Shaft $\varnothing 20$ mm // Ring set $\varnothing 35$ mm

Order No.	Name	
350050010	Universal assembly device $\varnothing 50$	
350040010	Clamping nut wrench PC27 for $\varnothing 20$	
350040011	Clamping nut wrench PC27 for $\varnothing 20$	
350040040	*Clamping nut wrench PC29 for $\varnothing 20$ for clamping nut with blancing option	
350040041	*Clamping nut wrench PC29 for $\varnothing 20$	
350020081	*Balancing weight pair for clamping nut $\varnothing 35$ // 40gmm	

Order No.	Name	
350012020	Spacer ring $\varnothing 35 \times \varnothing 20 \times 20$	
350012010	Spacer ring $\varnothing 35 \times \varnothing 20 \times 10$	
350012004	Spacer ring $\varnothing 35 \times \varnothing 20 \times 4$	
350015001	Reducing washer $\varnothing 50 \times \varnothing 35 \times \varnothing 20 \times 6$	
350030020	Lock washer $\varnothing 35 \times \varnothing 20 \times 2$	
350020030	Clamping nut $\varnothing 35 \times 6$ M20 x 1 PC27	
350020080	*Clamping nut with blancing option $\varnothing 35 \times \varnothing 40 \times 8 \times$ M20 x 1 PC29	
350015005	Support washer $\varnothing 35 \times \varnothing 60 \times \varnothing 20 \times 6$	

\*related items

# Walter HSK50 // Shaft $\varnothing 20$ mm // RS $\varnothing 50$ mm

For Walter tool grinding machines with ring set  $\varnothing 50$  mm

## GWA HSK50 // $\varnothing 20$ mm // RS $\varnothing 50$ mm

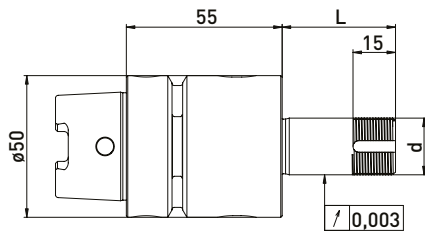
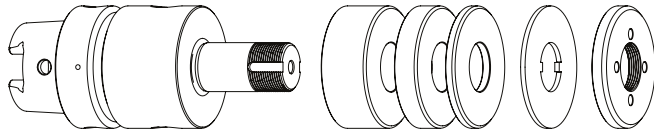

**Delivered equipped:**  
Ring set  $\varnothing 50$  mm, lock washer and clamping nut

## GWA HSK50 // $\varnothing 20$ mm // without RS

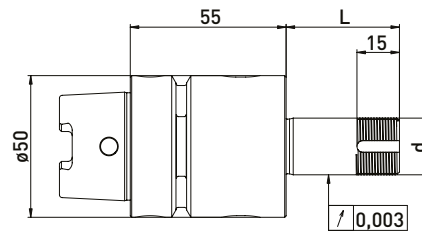
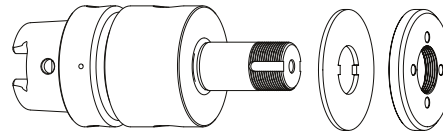

**Delivered equipped:**  
Lock washer and clamping nut

### Ring set $\varnothing 50$ mm

Order No.	HSK	d	L	B 20	B 10	B 4
300102012	HSK50	20	40	-	2	3
300102022	HSK50	20	60	1	2	3
300102032	HSK50	20	85	2	2	4
300102042	HSK50	20	100	2	3	5

Order No.	HSK	d	L
300102011	HSK50	20	40
300102021	HSK50	20	60
300102031	HSK50	20	85
300102041	HSK50	20	100

## Accessories Walter grinding wheel adapter HSK50 // Shaft $\varnothing 20$ mm // Ring set $\varnothing 50$ mm

Order No.	Name	
350050010	Universal assembly device $\varnothing 50$	
350040010	*Clamping nut wrench PC27 for $\varnothing 20$	
350040011	*Clamping nut wrench PC27 for $\varnothing 20$	
350020021	*Balancing weight pair for clamping nut $\varnothing 50$ // 100gmm	

Order No.	Name	
350011020	Spacer ring $\varnothing 50 \times \varnothing 20 \times 20$	
350011010	Spacer ring $\varnothing 50 \times \varnothing 20 \times 10$	
350011004	Spacer ring $\varnothing 50 \times \varnothing 20 \times 4$	
350015002	Reducing washer $\varnothing 40 \times \varnothing 50 \times \varnothing 20 \times 6$	
350020060	Clamping nut $\varnothing 50 \times 6 \times M20 \times 1$ PC27	
350020020	*Clamping nut with balancing option $\varnothing 50 \times 8,5 M20 \times 1,0$ PC27	

# Walter HSK50 // Shaft $\varnothing 31,75$ mm ( $1\frac{1}{4}$ ) // RS $\varnothing 60$ mm

For Walter tool grinding machines with ring set  $\varnothing 60$  mm

## GWA HSK50 // $\varnothing 31,75$ mm ( $1\frac{1}{4}$ ) // RS $\varnothing 60$ mm

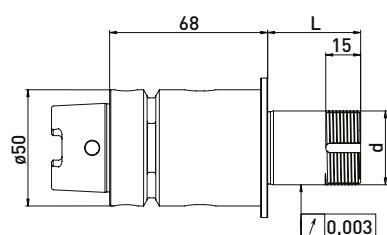
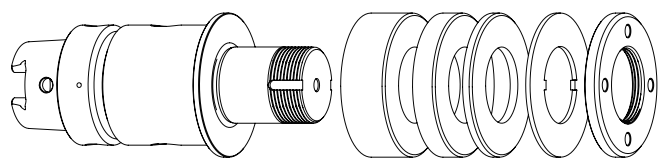

**Delivered equipped:**  
Ring set  $\varnothing 60$  mm, lock washer and clamping nut

## GWA HSK50 // $\varnothing 31,75$ mm ( $1\frac{1}{4}$ ) // without RS

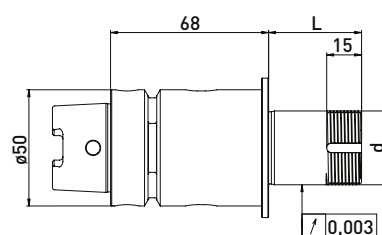
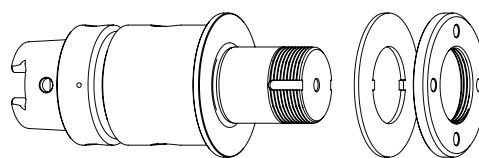

**Delivered equipped:**  
Lock washer and clamping nut

### Ring set $\varnothing 60$ mm

Order No.	HSK	d	L	B 20	B 10	B 4
300102112	HSK50	31,75	40	-	2	3
300102122	HSK50	31,75	60	1	2	3
300102132	HSK50	31,75	85	2	2	4
300102142	HSK50	31,75	100	3	2	3

Order No.	HSK	d	L
300102111	HSK50	31,75	40
300102121	HSK50	31,75	60
300102131	HSK50	31,75	85
300102141	HSK50	31,75	100

## Accessories Walter grinding wheel adapter HSK50 // Shaft $\varnothing 31,75$ mm ( $1\frac{1}{4}$ ) // Ring set $\varnothing 60$ mm

Order No.	Name	
350050010	Universal assembly device $\varnothing 50$	
350040030	*Clamping nut wrench PC39 for clamping nut with blancing option	
350040020	Clamping nut wrench PC45 for $\varnothing 32$	
350020023	*Balancing weight pair for clamping nut $\varnothing 60$ // 200gmm	

Order No.	Name	
350011420	Spacer ring $\varnothing 60 \times \varnothing 31,75 \times 20$	
350011410	Spacer ring $\varnothing 60 \times \varnothing 31,75 \times 10$	
350011404	Spacer ring $\varnothing 60 \times \varnothing 31,75 \times 4$	
350030060	Lock washer $\varnothing 60 \times \varnothing 32 \times 1,8$	
350020066	Clamping nut $\varnothing 60 \times 6 \times M32 \times 1,5$ PC45	
350020022	*Clamping nut with balancing option $\varnothing 60 \times 9$ M32 x 1,5 PC39	

\*related items

# Walter NCT // Shaft $\varnothing 20$ mm // RS $\varnothing 35$ mm

For Walter tool grinding machines with ring set  $\varnothing 35$  mm

## GWA NCT $\varnothing 31,75$ mm (1 1/4) // $\varnothing 20$ mm // RS $\varnothing 35$ mm

Tight with torque wrench 80Nm.

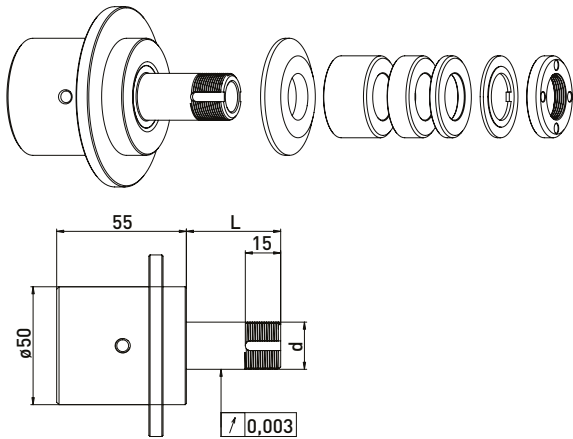

### Delivered equipped:

Reducing washer, ring set  $\varnothing 35$  mm, lock washer and clamping nut

#### Ring set $\varnothing 35$ mm

Order No.	Internal taper	d	L	B 20	B 10	B 4
300101512	31,75	20	40	-	1	3
300101522	31,75	20	60	1	1	3
300101542	31,75	20	85	2	1	4
300101532	31,75	20	100	2	3	3

## GWA NCT $\varnothing 31,75$ mm (1 1/4) // $\varnothing 20$ mm // without RS

Tight with torque wrench 80Nm.

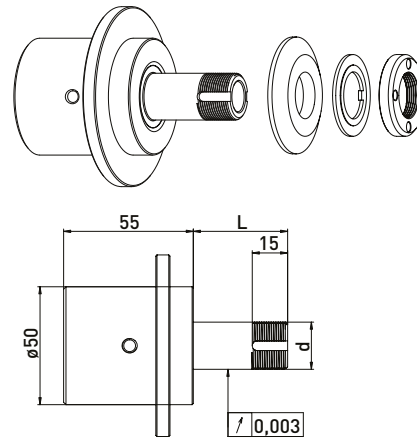

### Delivered equipped:

Reducing washer, lock washer and clamping nut

Order No.	Internal taper	d	L
300101511	31,75	20	40
300101521	31,75	20	60
300101541	31,75	20	85
300101531	31,75	20	100

## Accessories Walter grinding wheel adapter NCT // Shaft $\varnothing 20$ mm // Ring set $\varnothing 35$ mm

Order No.	Name	
350050010	Universal Assembly device $\varnothing 50$	
350040010	Clamping nut wrench PC27 for $\varnothing 20$	
350040011	Clamping nut wrench PC27 for $\varnothing 20$	
350040040	*Clamping nut wrench PC29 for $\varnothing 20$ for clamping nut with blancing option	
350040041	*Clamping nut wrench PC29 for $\varnothing 20$	
350020081	*Balancing weight pair for clamping nut $\varnothing 35$ // 40gmm	
300101001	Installation kit for NCT63 Walter	
300101003	Assembly wrench for installation kit NCT63 M20 x 1,5	

Order No.	Name	
350012020	Spacer ring $\varnothing 35$ x $\varnothing 20$ x 20	
350012010	Spacer ring $\varnothing 35$ x $\varnothing 20$ x 10	
350012004	Spacer ring $\varnothing 35$ x $\varnothing 20$ x 4	
350015001	Reducing washer $\varnothing 50$ x $\varnothing 35$ x $\varnothing 20$ x 6	
350030020	Lock washer $\varnothing 35$ x $\varnothing 20$ x 2	
350020030	Clamping nut $\varnothing 35$ x 6 M20 x 1 PC27	
350020080	*Clamping nut with blancing option $\varnothing 35$ x $\varnothing 40$ x 8 x M20 x 1 PC29	
350015005	Support washer $\varnothing 35$ x $\varnothing 60$ x $\varnothing 20$ x 6	

# Walter NCT // Shaft $\varnothing 20$ mm // RS $\varnothing 50$ mm

For Walter tool grinding machines with ring set  $\varnothing 50$  mm

## GWA NCT $\varnothing 31,75$ mm (1 1/4) // $\varnothing 20$ mm // RS $\varnothing 50$ mm

Tight with torque wrench 80Nm.

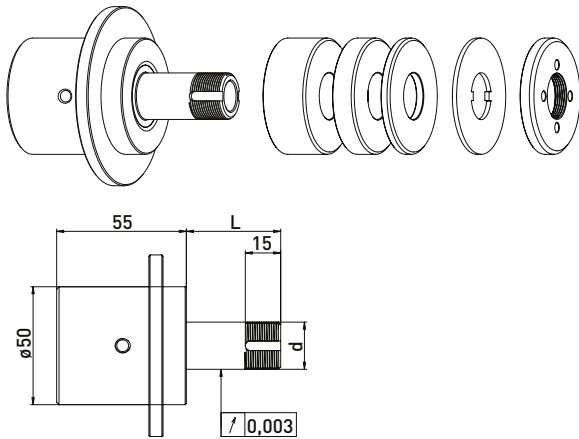

Delivered equipped:  
Ring set  $\varnothing 50$  mm, lock washer and clamping nut

## GWA NCT $\varnothing 31,75$ mm (1 1/4) // $\varnothing 20$ mm // without RS

Tight with torque wrench 80Nm.

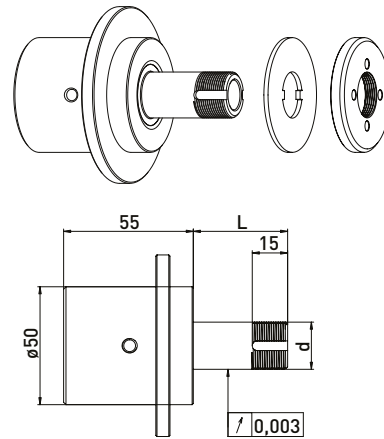

Delivered equipped:  
Lock washer and clamping nut

### Ring set $\varnothing 50$ mm

Order No.	Internal taper	d	L	B 20	B 10	B 4
300101012	31,75	20	40	-	1	3
300101022	31,75	20	60	1	1	3
300101042	31,75	20	85	2	1	4
300101032	31,75	20	100	2	3	3

Order No.	Internal taper	d	L
300101011	31,75	20	40
300101021	31,75	20	60
300101041	31,75	20	85
300101031	31,75	20	100

## Accessories Walter grinding wheel adapter NCT // Shaft $\varnothing 20$ mm // Ring set $\varnothing 50$ mm

Order No.	Name	
350050010	Universal Assembly device $\varnothing 50$	
350040010	*Clamping nut wrench PC27 for $\varnothing 20$	
350040011	*Clamping nut wrench PC27 for $\varnothing 20$	
350040040	*Clamping nut wrench PC29 for $\varnothing 20$ for clamping nut with blancing option	
350040041	*Clamping nut wrench PC29 for $\varnothing 20$	
350020021	*Balancing weight pair for clamping nut $\varnothing 50$ // 100gmm	
300101001	Installation kit for NCT63 Walter	
300101003	Assembly wrench for installation kit NCT63 M20 x 1,5	

Order No.	Name	
350011020	Spacer ring $\varnothing 50$ x $\varnothing 20$ x 20	
350011010	Spacer ring $\varnothing 50$ x $\varnothing 20$ x 10	
350011004	Spacer ring $\varnothing 50$ x $\varnothing 20$ x 4	
350030010	Lock washer $\varnothing 50$ x $\varnothing 20$ x 2	
350020060	Clamping nut $\varnothing 50$ x 6 x M20 x 1 PC27	
350020020	*Clamping nut with balancing option $\varnothing 50$ x 8,5 M20 x 1,0 PC27	

\*related items

# Walter NCT // Shaft $\varnothing 31,75$ mm ( $1\frac{1}{4}$ ) // RS $\varnothing 60$ mm

For Walter tool grinding machines with ring set  $\varnothing 60$  mm

## GWA NCT $\varnothing 31,75$ mm // $\varnothing 31,75$ mm ( $1\frac{1}{4}$ ) // RS $\varnothing 60$ mm

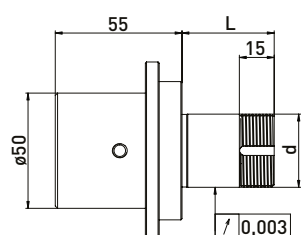
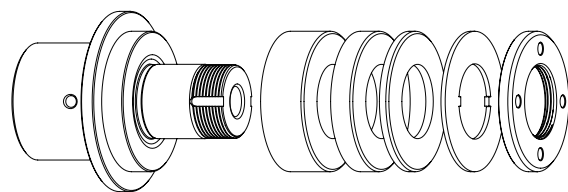

**Delivered equipped:**  
Ring set  $\varnothing 60$  mm, lock washer and clamping nut

## GWA NCT $\varnothing 31,75$ mm ( $1\frac{1}{4}$ ) // $\varnothing 31,75$ mm ( $1\frac{1}{4}$ ) // without RS

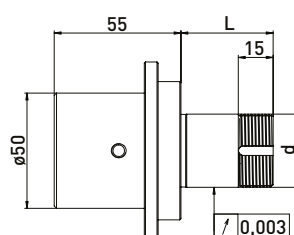
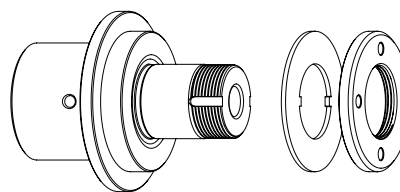

**Delivered equipped:**  
Lock washer and clamping nut

### Ring set $\varnothing 60$ mm

Order No.	Internal taper	d	L	B 20	B 10	B 4
300101112	31,75	31,75	40	-	1	5
300101122	31,75	31,75	60	1	1	5
300101132	31,75	31,75	85	1	4	4
300101142	31,75	31,75	100	2	3	5

Order No.	Internal taper	d	L
300101111	31,75	31,75	40
300101121	31,75	31,75	60
300101131	31,75	31,75	85
300101141	31,75	31,75	100

## Accessories Walter grinding wheel adapter NCT // Shaft $\varnothing 31,75$ mm ( $1\frac{1}{4}$ ) // Ring set $\varnothing 50$ mm

Order No.	Name	
350050010	Universal Assembly device $\varnothing 50$	
350040030	*Clamping nut wrench PC39 for clamping nut with blancing option	
350040020	Clamping nut wrench PC45 for $\varnothing 32$	
350020023	*Balancing weight pair for clamping nut $\varnothing 60$ // 200gmm	
300101001	Installation kit for NCT63 Walter	
300101003	Assembly wrench for installation kit NCT63 M20 x 1,5	

Order No.	Name	
350011420	Spacer ring $\varnothing 60$ x $\varnothing 31,75$ x 20	
350011410	Spacer ring $\varnothing 60$ x $\varnothing 31,75$ x 10	
350011404	Spacer ring $\varnothing 60$ x $\varnothing 31,75$ x 4	
350030060	Lock washer $\varnothing 60$ x $\varnothing 32$ x 1,8	
350020066	Clamping nut $\varnothing 60$ x 6 x M32 x 1,5 PC45	
350020022	*Clamping nut with balancing option $\varnothing 60$ x 9 M32 x 1,5 PC39	